

Exterior Rear
 1/8 in = 1 ft





Exterior Left
 1/8 in = 1 ft

RECEIVED	
	Sep 24 2024
	<i>Amy Beth Laythe</i> Administrative Assistant Planning & Regulatory Services Division

LAYOUT PAGE TABLE	
LABEL	TITLE
P-1	ELEVATIONS
P-2	PLOT PLAN
P-3	FIRST FLOOR PLAN
P-4	SECOND FLOOR PLAN
P-5	FOUNDATION PLAN
P-6	SECOND FLOOR FRAMING
P-7	CEILING/ROOF FRAMING PLAN
P-8	CROSS SECTION & SCHEDULES
P-9	SECTION 1

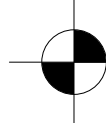

Exterior Right
 1/8 in = 1 ft

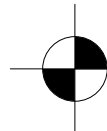

Exterior Front (Street Side)
 1/8 in = 1 ft

SHEET TITLE:
Elevations

PROJECT DESCRIPTION:
 Proposed Two Family -
 35 Greendale Ave Worcester, MA
 Owner: IGOR Construction

DRAWINGS PROVIDED BY:
 Tom Hawkins Building and Design
 505 Plantation St #222, Worcester, MA 01605
 tom@hawkins-builder.com 508-735-7734

DATE:

4/8/2024

SCALE:

SHEET:

P-1

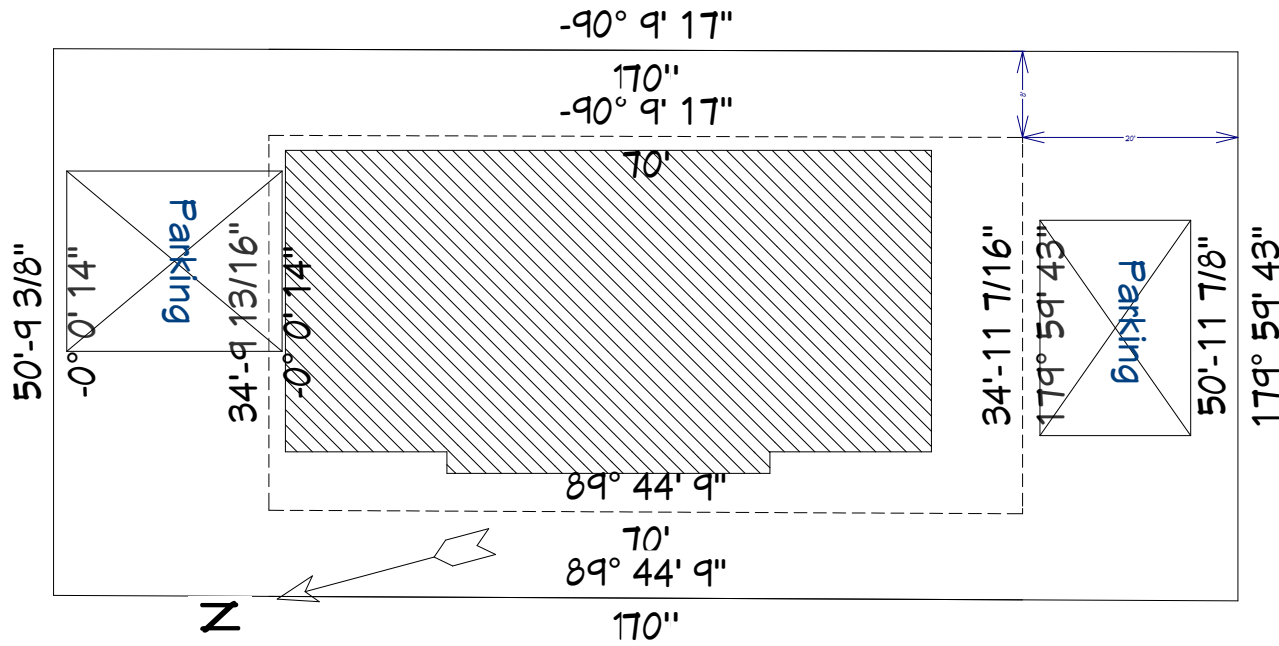

GREENDALE AVE

Plot Plan
1/8 in = 1 ft

SHEET TITLE:

Plot Plan

PROJECT DESCRIPTION:
Proposed Two Family -
35 Greendale Ave Worcester, MA
Owner: IGOR Construction

DRAWINGS PROVIDED BY:
Tom Hawkins Building and Design
505 Plantation St #222, Worcester, MA 01605
tom@hawkins-builder.com 508-735-7734

DATE:
4/8/2024

SCALE:

SHEET:
P-2

NOTE - Smoke Detector and CO alarms are of the Photoelectric Type and are hardwired.
HEAT alarms are tied to the common circuit!

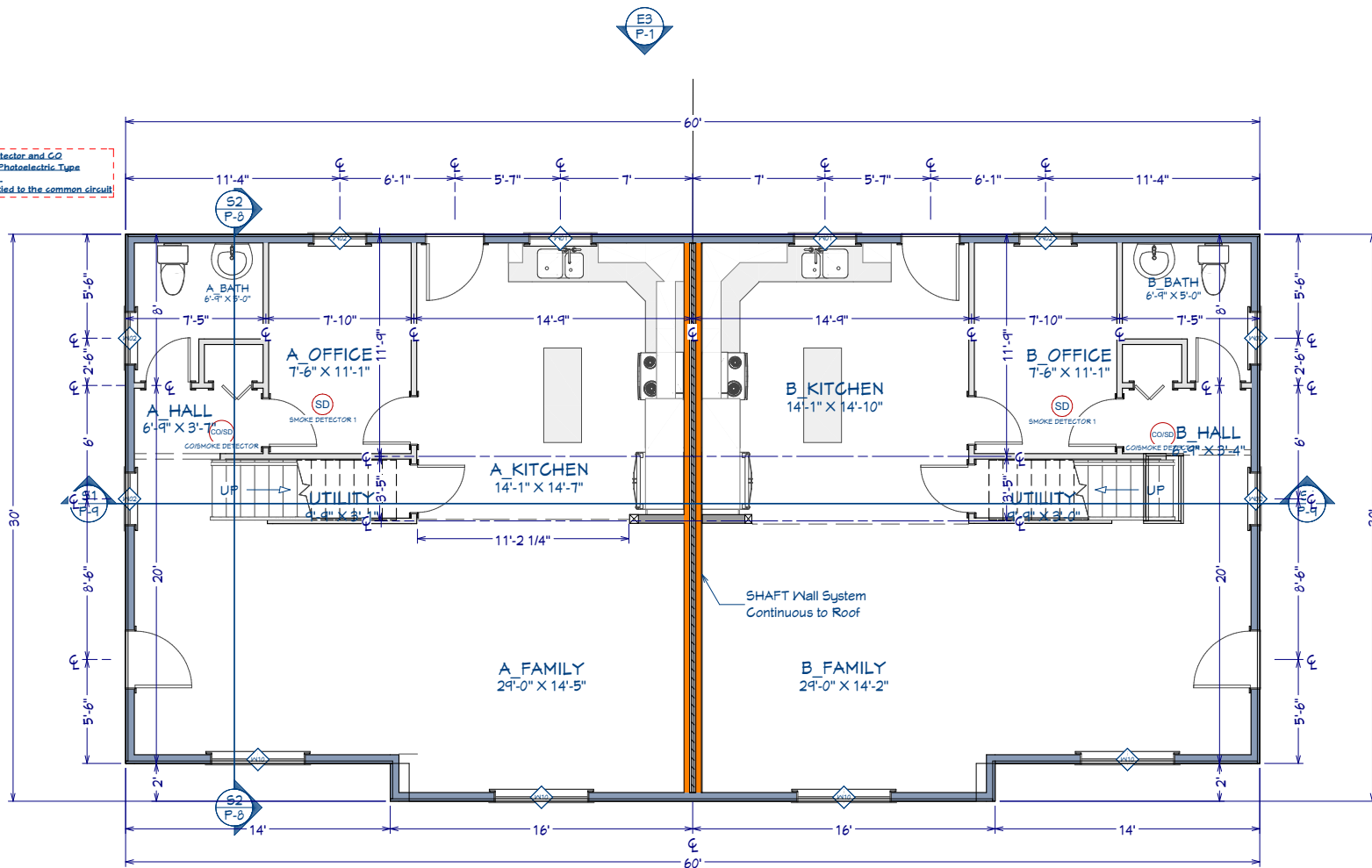

LIVING AREA
1744 SQ FT

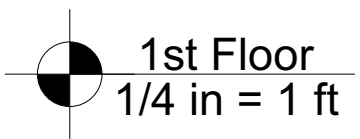

SHEET TITLE:

First Floor Plan

PROJECT DESCRIPTION:

Proposed Two Family -
35 Greendale Ave Worcester, MA
Owner: IGOR Construction

DRAWINGS PROVIDED BY:

Tom Hawkins Building and Design
505 Plantation St #222, Worcester, MA 01605
tom@hawkins-builder.com 508-735-7734

DATE:

4/8/2024

SCALE:

SHEET:

P-3

Smoke Detector and CO
are of the Photoelectric Type
& hardwired.
alarms are tied to the common circuit!

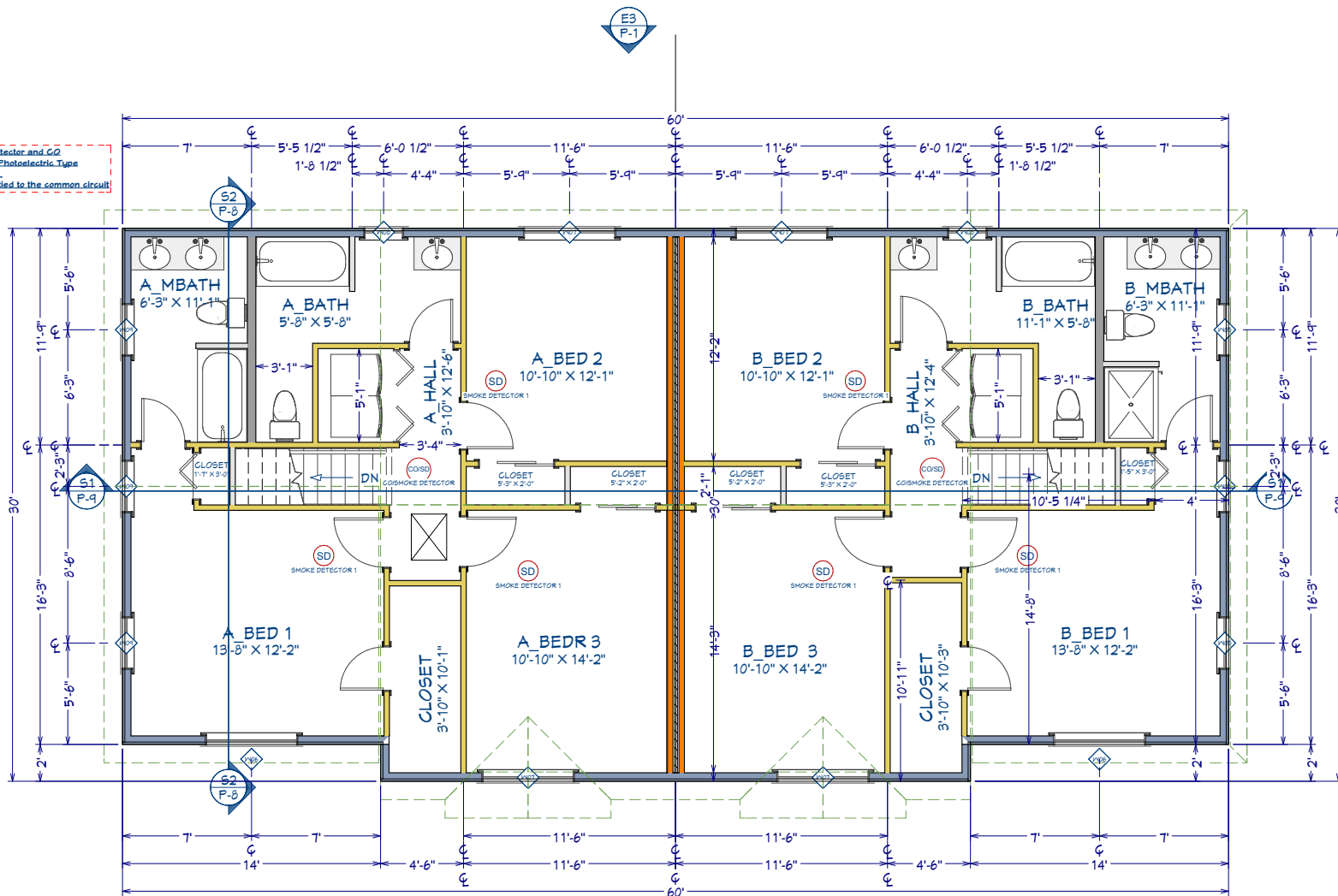

LIVING AREA
1715 SQ FT

 **2nd Floor**
1/4 in = 1 ft

SHEET TITLE:
Second Floor Plan

PROJECT DESCRIPTION:
Proposed Two Family -
35 Greendale Ave Worcester, MA
Owner: IGOR Construction

DRAWINGS PROVIDED BY:
Tom Hawkins Building and Design
505 Plantation St #222, Worcester, MA 01605
tom@hawkins-builder.com 508-735-7734

DATE:

4/8/2024

SCALE:

SHEET:

P-4

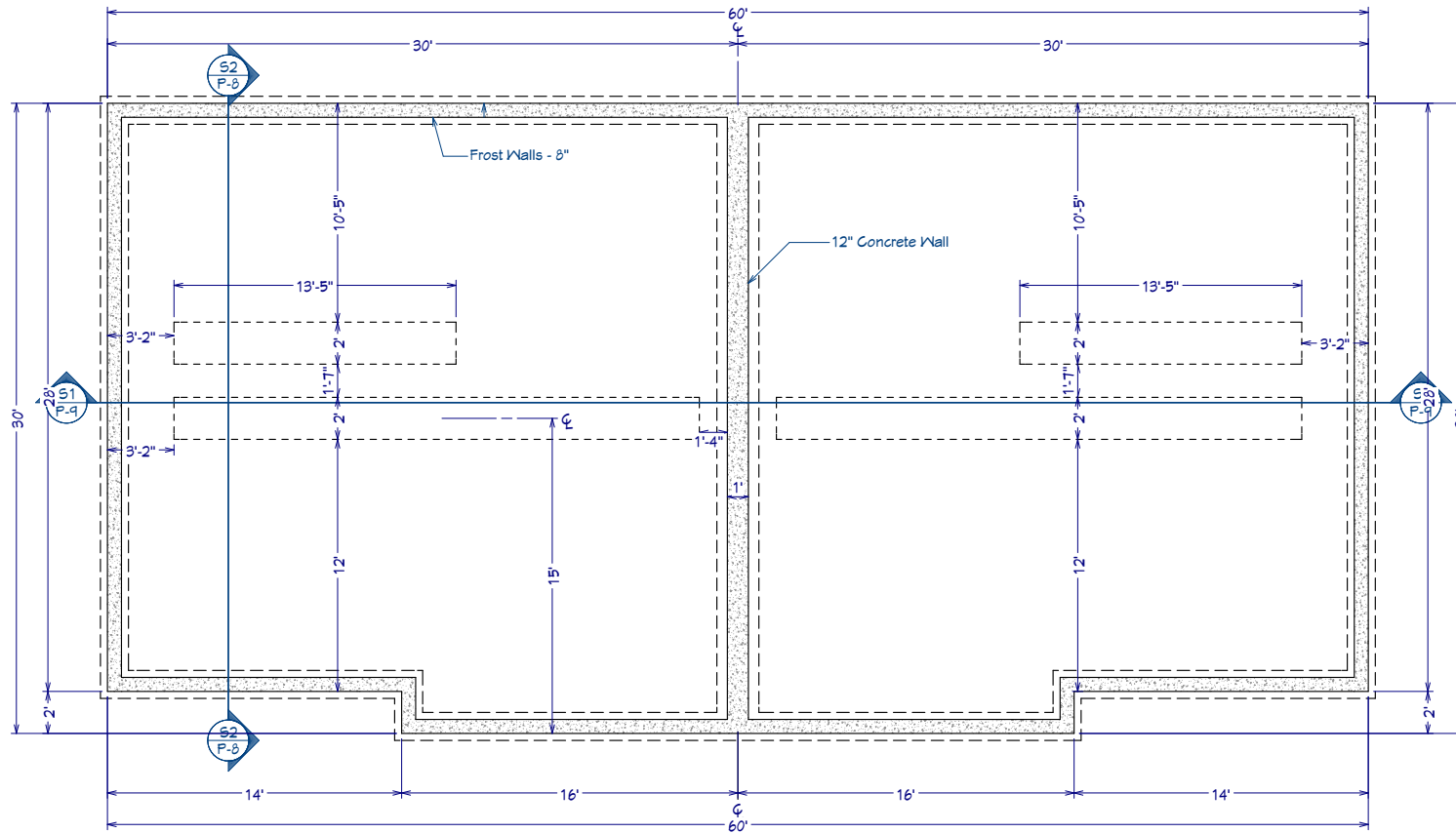

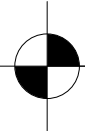
Foundation Plan
 1/4 in = 1 ft

E1
P-1

SHEET TITLE:

Foundation Plan

PROJECT DESCRIPTION:

Proposed Two Family -
 35 Greendale Ave Worcester, MA
 Owner: IGOR Construction

DRAWINGS PROVIDED BY:

Tom Hawkins Building and Design
 505 Plantation St #222, Worcester, MA 01605
 tom@hawkins-builder.com 508-735-7734

DATE:

4/8/2024

SCALE:

SHEET:

P-5

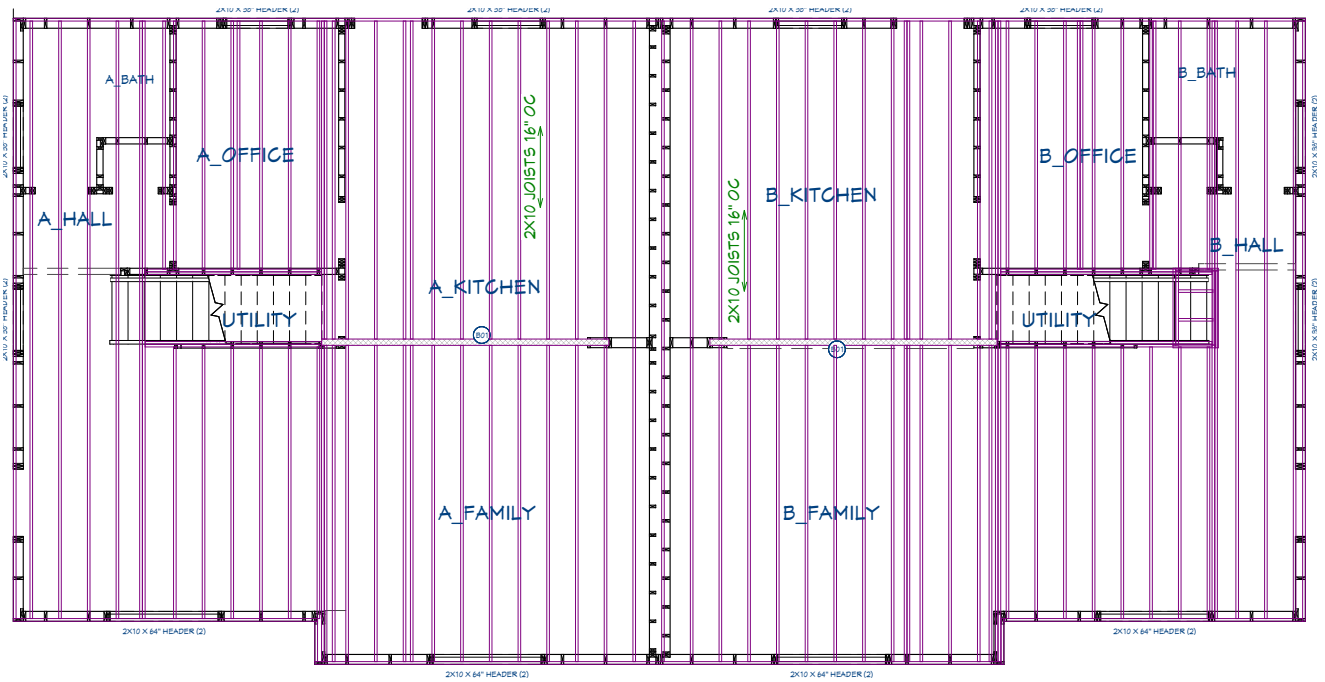

LIVING AREA
1744 SQ FT

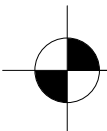

Framing - Second Floor
1/4 in = 1 ft

SHEET TITLE:

Second Floor Framing

PROJECT DESCRIPTION:

Proposed Two Family -
35 Greendale Ave Worcester, MA
Owner: IGOR Construction

DRAWINGS PROVIDED BY:

Tom Hawkins Building and Design
505 Plantation St #222, Worcester, MA 01605
tom@hawkins-builder.com 508-735-7734

DATE:

4/8/2024

SCALE:

SHEET:

P-6

Framing - Ceiling
1/4 in = 1 ft

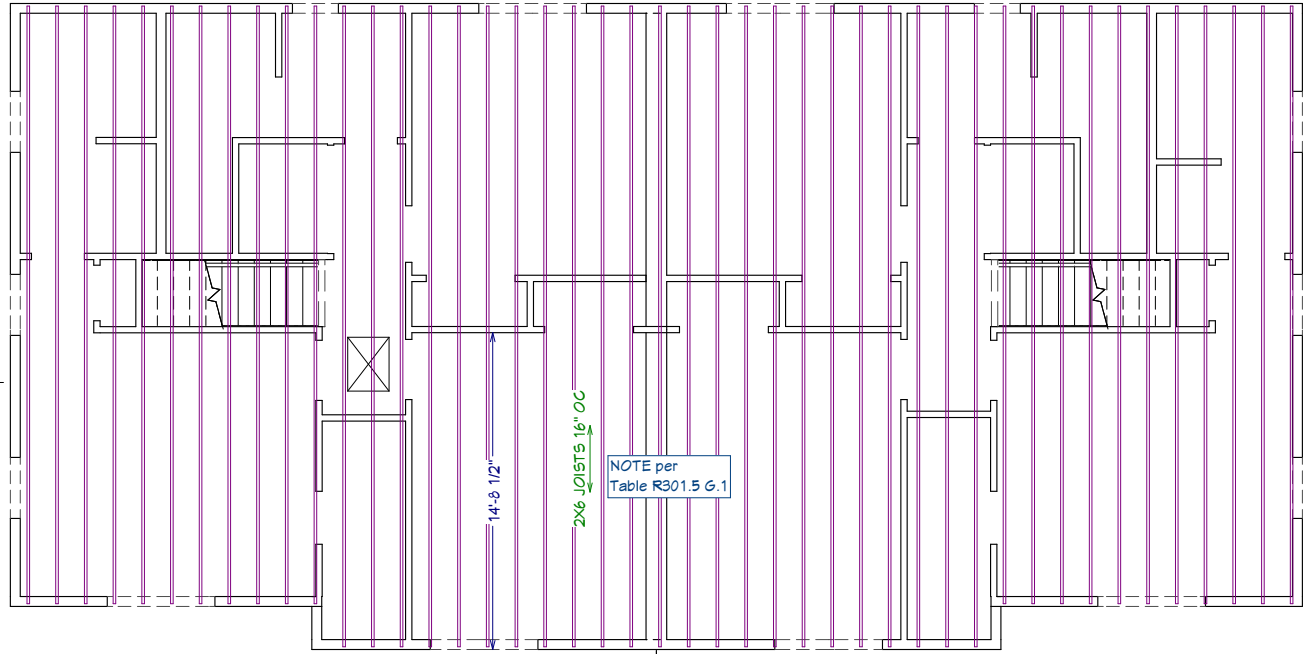

Framing - Roof Second Floor
1/4 in = 1 ft

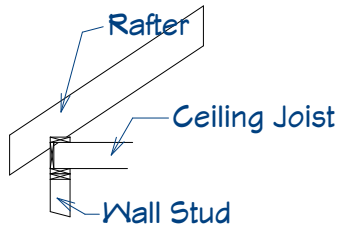
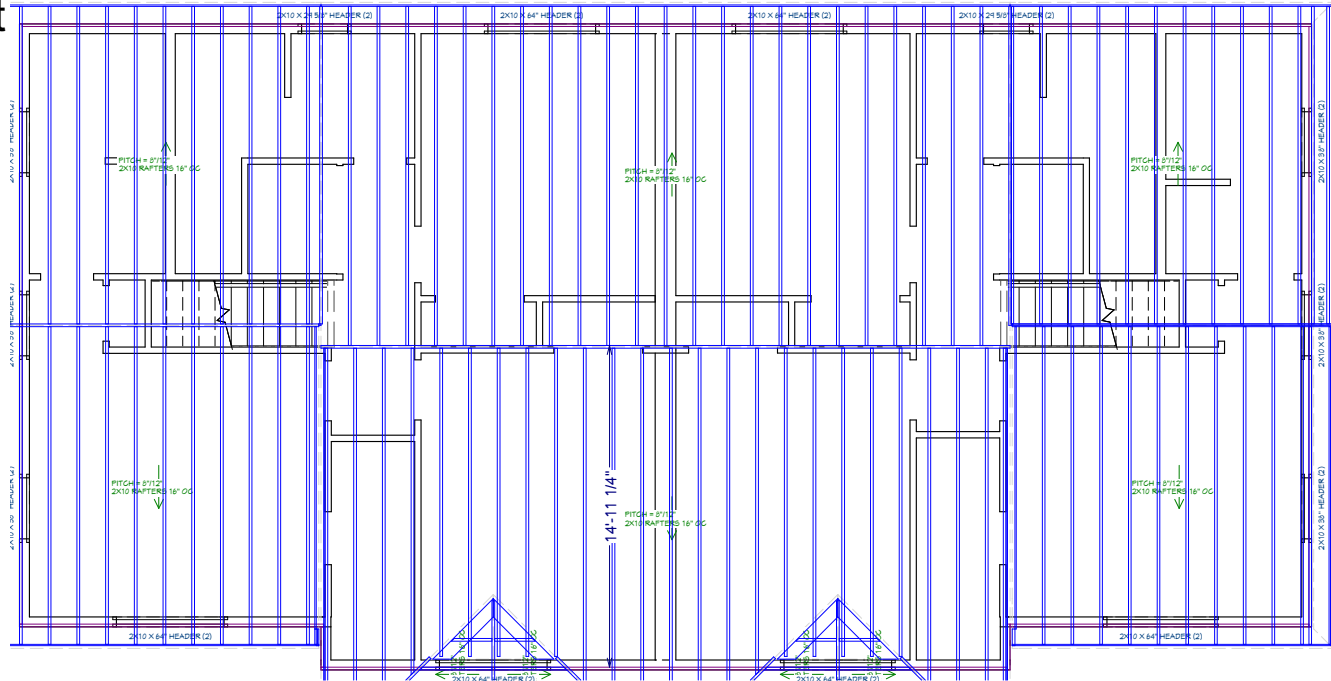

Ceiling/Roof Detail
1/2 in = 1 ft

NOTE per Table R301.5 G.1

SHEET TITLE:

Ceiling/Roof Framing Plan

PROJECT DESCRIPTION:

Proposed Two Family -
35 Greendale Ave Worcester, MA
Owner: IGOR Construction

DRAWINGS PROVIDED BY:

Tom Hawkins Building and Design
505 Plantation St #222, Worcester, MA 01605
tom@hawkins-builder.com 508-735-7734

DATE:

4/8/2024

SCALE:

SHEET:

P-7

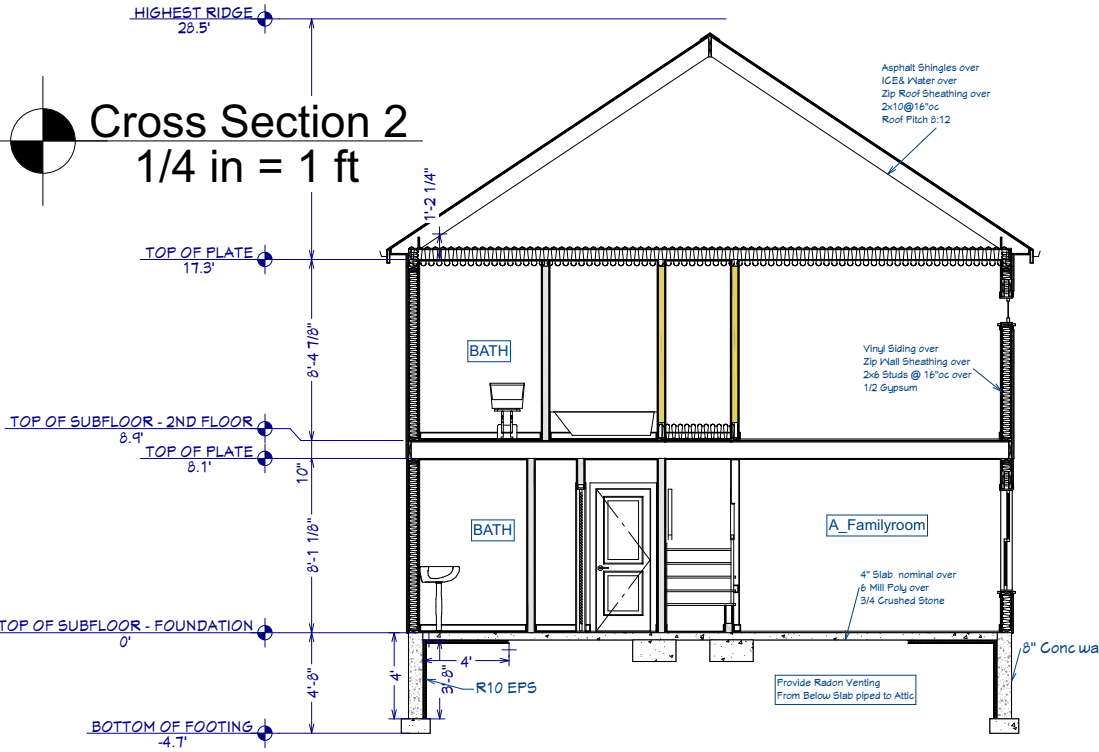

Cross Section 2
1/4 in = 1 ft

Schedules
1/8 in = 1 ft

BEAM SCHEDULE

NUMBER	QTY	FLOOR	HEIGHT	WIDTH	LENGTH	TYPE	COMMENTS
B01	2	1-2	13.12'	13.4'		LVL	

WINDOW SCHEDULE

NUMBER	QTY	FLOOR	NO.	DESCRIPTION	AREA STANDARD
W01	2	1	4110X1	DOUBLE HUNG	11.19
W02	16	1	3310X8	DOUBLE HUNG	13.46
W03	3	2	3310X8	DOUBLE HUNG	13.31
W04	2	2	4110X1	FIXED GLASS	8.26
W05	2	2	4110X8	DOUBLE UNIT	16.78
W06	2	2	2410X21 1/2	DOUBLE HUNG	8.5
W07	2	2	3310X8	DOUBLE HUNG	13.46
W08	4	1	4110X8	MULLED UNIT	26.78
TOTALS:	4	1	4110X8	MULLED UNIT	104.11

DOOR SCHEDULE

NUMBER	QTY	FLOOR	NO.	DESCRIPTION	AREA STANDARD
D01	2	1	3010X2 1/2	HINGED DOOR P01	13.36
D02	2	1	4410X2 1/2	P.R. BIPART. COVERED	13.33
D03	16	1	3010X2 1/2	HINGED DOOR P01	16.81
D04	4	1	3010X2 1/2	HINGED DOOR P01	49
D05	14	2	3010X2 1/2	HINGED DOOR P01	16.81
D06	2	2	4110X2 1/2	P.R. BIPART. COVERED	16.36
D07	14	2	3010X2 1/2	HINGED DOOR P01	26.81
D08	14	2	3010X2 1/2	HINGED DOOR P01	16.36
D09	4	2	3410X2 1/2	HINGED DOOR P01	13.36
D10	2	2	4410X2 1/2	P.R. BIPART. COVERED	16.33
TOTALS:	7	2	4410X2 1/2	P.R. BIPART. COVERED	852.44

NOTE - Smoke Detector and CO Alarms are of the Photoelectric Type and are hardwired. HEAT alarms are tied to the common circuit

FIRE DETECTION SCHEDULE

FLOOR	ROOM NAME	QTY	AS SYMBOL	DESCRIPTION	COMMENTS
1	A_HALL	1	☉	CO/SMOKE DETECTOR	
1	A_OFFICE	1	☉	SMOKE DETECTOR 1	
1	B_HALL	1	☉	CO/SMOKE DETECTOR	
1	B_OFFICE	1	☉	SMOKE DETECTOR 1	
2	A_BED 1	1	☉	SMOKE DETECTOR 1	
2	A_BED 2	1	☉	SMOKE DETECTOR 1	
2	A_BED 3	1	☉	SMOKE DETECTOR 1	
2	A_HALL	1	☉	CO/SMOKE DETECTOR	
2	B_BED 3	1	☉	SMOKE DETECTOR 1	
2	B_BED 1	1	☉	SMOKE DETECTOR 1	
2	B_BED 2	1	☉	SMOKE DETECTOR 1	
2	B_HALL	1	☉	CO/SMOKE DETECTOR	
3	A_ATTIC	2	☉	HEAT DETECTOR	
3	B_ATTIC	2	☉	HEAT DETECTOR	

SHEET TITLE:
Cross section & Schedules

PROJECT DESCRIPTION:
Proposed Two Family -
35 Greendale Ave Worcester, MA
Owner: IGOR Construction

DRAWINGS PROVIDED BY:
Tom Hawkins Building and Design
505 Plantation St #222, Worcester, MA 01605
tom@hawkins-builder.com 508-735-7734

DATE:

4/8/2024

SCALE:

SHEET:

P-8

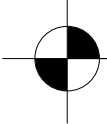
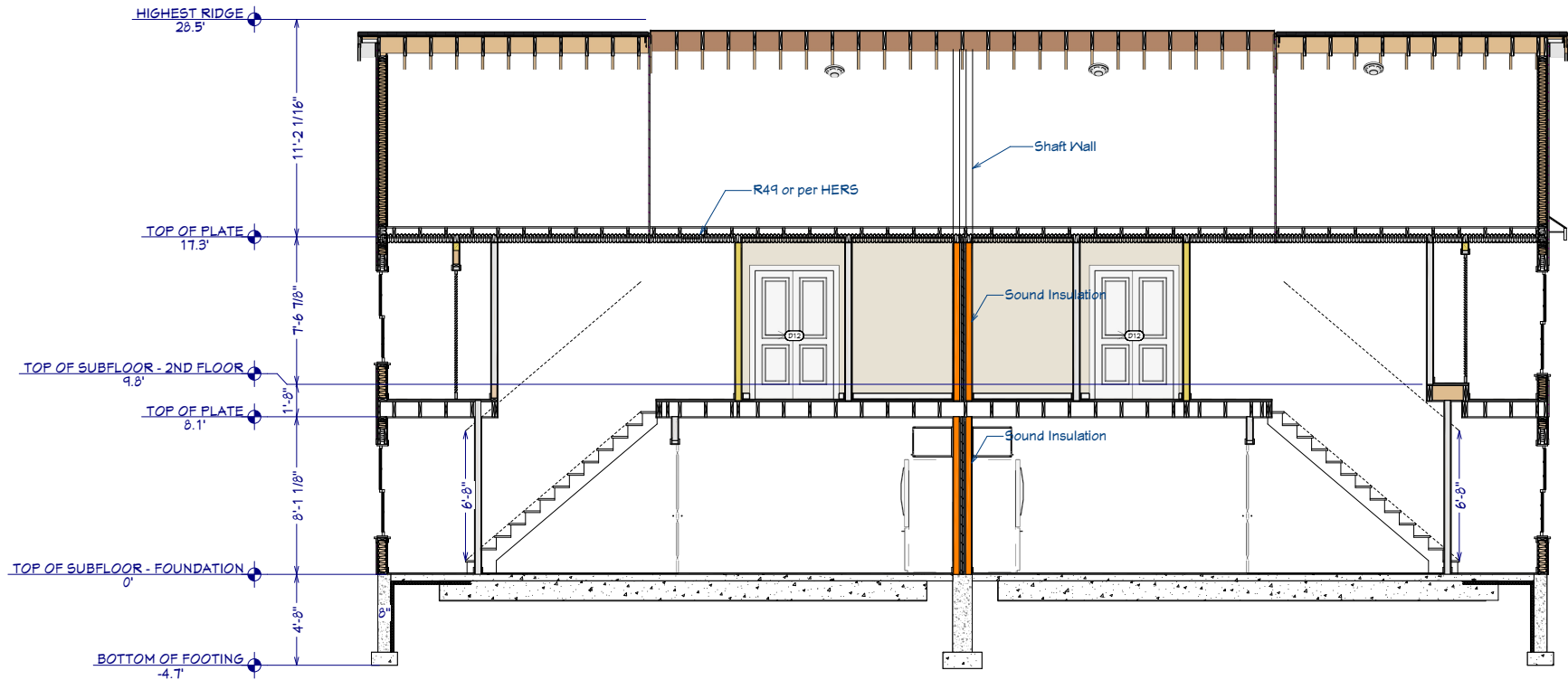

Cross Section 1
 1/4 in = 1 ft

SHEET TITLE:

Section 1

PROJECT DESCRIPTION:

Proposed Two Family -
 35 Greendale Ave Worcester, MA
 Owner: IGOR Construction

DRAWINGS PROVIDED BY:

Tom Hawkins Building and Design
 505 Plantation St #222, Worcester, MA 01605
 tom@hawkins-builder.com 508-735-7734

DATE:

4/8/2024

SCALE:

SHEET:

P-9